

EM150-BL70

Features

- Brushless motor with built-in driver
- High efficiency
- Low vibration
- Stainless steel blade
- Controller with RS-485 interface available

Applications

- Commercial food equipment
- Pellet stove
- Pumps
- Custom solutions

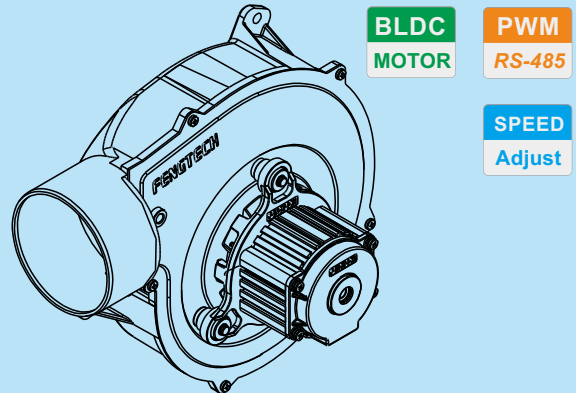

Drawings

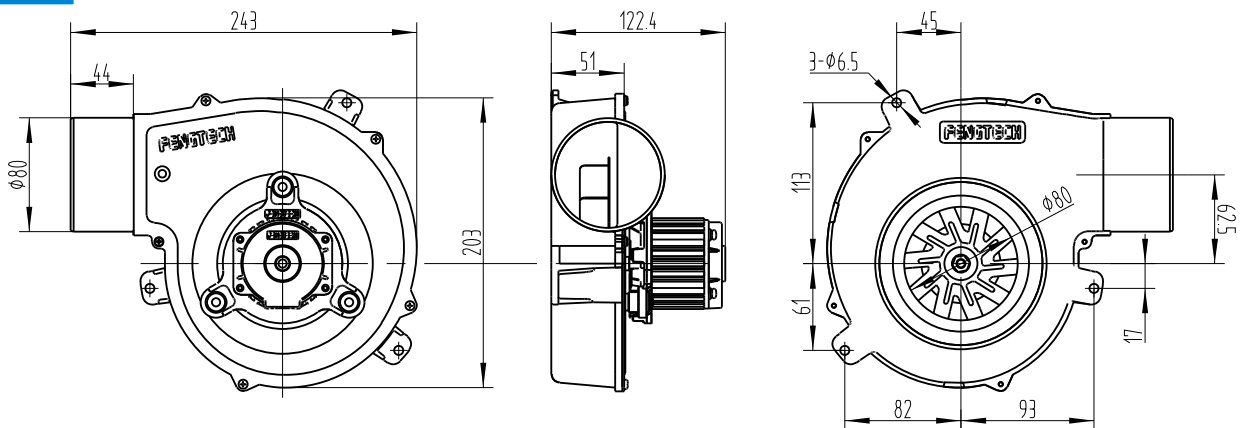

Specifications

ITEM	SPECIFICATION
Input Voltage	12 or 24 VDC
Input Power	20 ~ 60 W
Speed Range	0 ~ 2800 RPM
Output Power	12 ~ 45 W
Tachometer	9 PPR
Rotate Direction	Bi-directional
Current Limit	1.0 ~ 5.0 A

STANDARD MOTOR SPEED (NO-LOAD)					
1000	1500	2000	2800		

--	--	--	--	--	--

Safety

ITEM	SPECIFICATION
Insulation Resistance	100 M ohm
Insulation Class	Class E
Electric Strength	DC500V 1sec.
Environment	Temp: -20 ~ 45°C / Humidity: <85%
Protection	Impedance or thermal protection
Certification	CE CCC RoHS

INTEGRATED CONTROLLER WIRING			
PIN	COLOR	SYMBOL	DESCRIPTION
1	RED	VCC	Input power
2	RED	VCC	Input power
3	GREEN	Vsp / A	Speed control input / 485 BUS A
4	WHITE	FG / B	Rotation speed output / 485 BUS B
5	BLACK	GND	Power ground
6	BLACK	GND	Power ground